

Threading machine A33

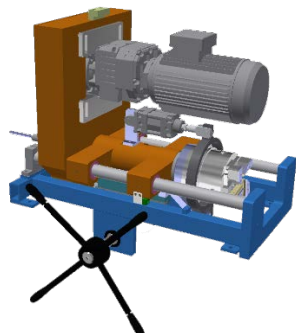

Advantages

User-friendly machine for big production that allows a rapid realisation of threads by tangential chasers.

Optimisation of the production costs thank to the possibility to regrind the chasers.

Precise set-up of the work speed, depending on the kind of steel you use.

Threading capacity

- ✓ Diameter from 8 to 33 mm or from 3/8" to 1 1/4"
- ✓ Every kind of thread: cylindric or conic.
- ✓ Right or left hand thread.
- ✓ Standard threading lenght: 115 mm.

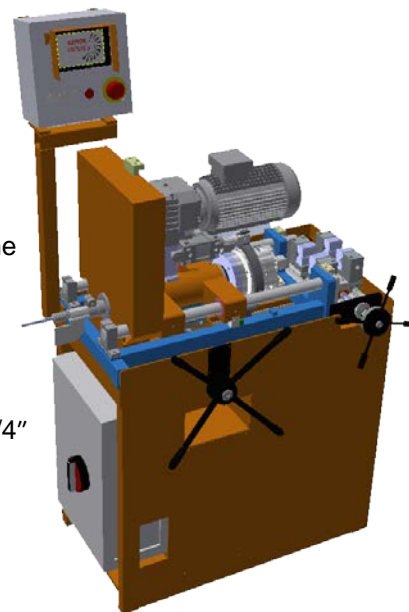

Operating

- ✓ Mobile and compact unit with a gearmotor and a transmission realized by trapezoidal belts, that activate a rotating mandrel. On the mandrel there is an automatic opening/closing head R33.
- ✓ Manual movement of the threading unit on recirculating ball sleeves.
- ✓ Self-centering and manual clamp (pneumatic in an option) with a V clamping jaw (2 V clamping jaws are an option).
- ✓ Pneumatic and automatic opening/closing threading head.
- ✓ Set-up of the threading length inside of the mandrel.
- ✓ Customized monitor 5", that allows to set-up the rotation speed of the mandrel according to the cutting parameters, diameter and thread pitch.
- ✓ Simplified mounting and set up of the chasers.
- ✓ Resharpenable chasers.
- ✓ Automatic watering.

Costruction

- ✓ Welded Base.
- ✓ Diameter of the spindle way of 34 mm.
- ✓ Chip tray and oil reservoir (soluble or plein oil).
- ✓ Crankcase on rotating elements.
- ✓ Electric cabinet (included safeties standard CE).
- ✓ Head R33 with set of chasers-holder.



CERGIL Industry S.r.l.

Sede legale: Via Fieno 3 – 20123 Milano

Sede operativa: Via degli Artigiani 2-4, Loc. Prado – 27010 Cura Carpignano (PV) - IT

www.cergil.it phone number +39 (0)382 465089 fax number +39 (0)382 461468

E-mail info@cergil.it

Codice fiscale e partita IVA 08295050960



Technical and electrical features



- ✓ 400 volts 3 KW Three-phase 50/60 Hz.
- ✓ 4-pole Engine 3 Kw 1400 rev/min.
- ✓ Electric power from 3 to 5,2 kW.
- ✓ Standard reduction 7.96.
- ✓ Mandrel speed from 50,28 to 181 rev/min.
- ✓ Electronic speed variator 7,5 KW with dynamic braking.
- ✓ Maximum torque on the spindle of 590 Nm.
- ✓ Watering pump 0.53 kW.
- ✓ Standard CE.

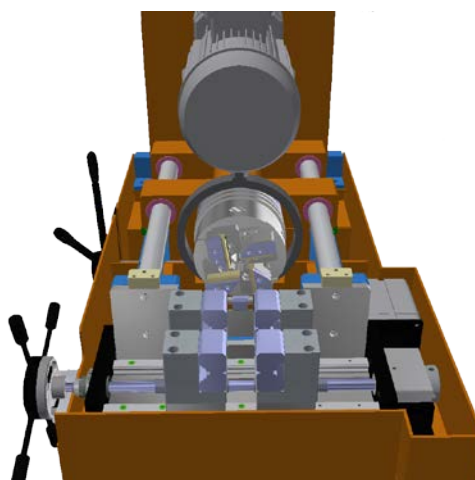

Options

- ✓ Automatic and pneumatic clamp.

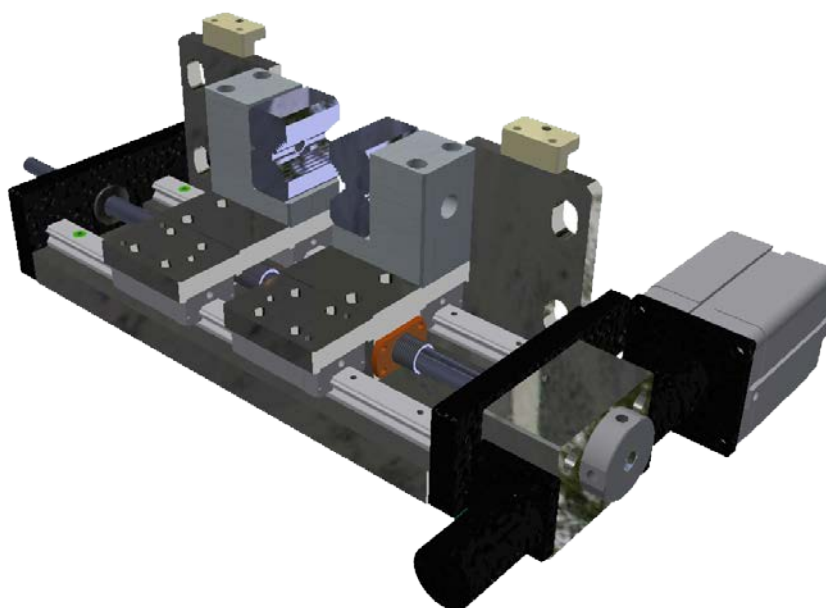

CERGIL Industry S.r.l.

Sede legale: Via Fieno 3 – 20123 Milano

Sede operativa: Via degli Artigiani 2-4, Loc. Prado – 27010 Cura Carpignano (PV) - IT

www.cergil.it phone number +39 (0)382 465089 fax number +39 (0)382 461468

E-mail info@cergil.it

Codice fiscale e partita IVA 08295050960

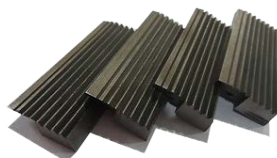

✓ Double clamp.

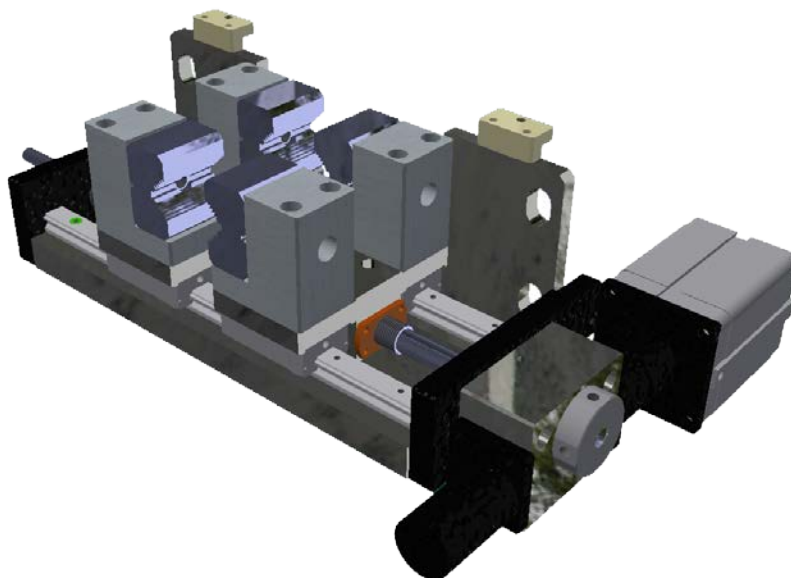

✓ Chasers-holder for tubes from 1" till 2".

✓ Wheels for construction site.

✓ Worktable.

✓ Grinding machine.

